



Redwood Engineering (UK) Ltd.,
Snowdon Rd. Nth.,
Queensway Ind. Est.,
St. Annes on Sea,
Lancashire.,
FY8 3DP.

Tel : 0044 (0)1253 713266

Fax : 0044 (0)1253 728233

E-Mail : www.offroadkartplans.com

BUILD YOUR OWN RALLY KART

OPTIONS : WASP 2-SEATER PLANS.



Fully illustrated
build manual.



Step by step
assembly
&
maintenance
manual.



Parts pricelists
&
kit prices.



Features include:

Fully illustrated plans & build manual, includes drawings & written instructions.

Maintenance & Inspection manual, a complete guide to servicing is included with every plan set.

Full technical advisory service for all your kart build questions.

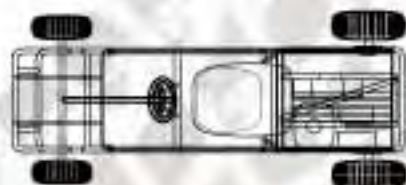
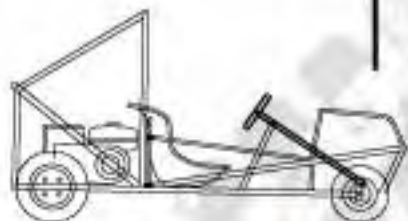



Redwood Engineering (UK) Ltd.,
Snowdon Rd. Nth.,
Queensway Ind. Est.,
St. Annes on Sea,
Lancashire.,
FY8 3DP.

Tel : 0044 (0)1253 713266

Fax : 0044 (0)1253 728233

E-Mail : www.offroadkartplans.com

CONDITIONS OF PURCHASE.

Please note that the sale of plans & parts for home builders is the companies 'livelihood' without which the company would not be able to supply : service, help or parts to the home builder.

Please respect the following. ©

The F350 & F500t / 2-seater plan sets are protected by copyright. Redwood Engineering (UK) Ltd. 1991. No part of these documents may be reproduced, copied, transferred to computer or transmitted in any form by any means, electronic or mechanical, for any purpose. unless you have the written permission of Redwood Engineering (UK) Ltd..

Legal action will be taken against any individual, individuals, or business making financial &/or commercial gain from reproducing either these plans, components or vehicles derived from these plans & designs.

Although every possible care has been taken to make these plans as complete & accurate as possible, no liability can be accepted for any inaccuracies or omissions in this publication.

The right is reserved to make changes at any time without prior notice & without incurring an obligation to make such changes to products manufactured previously.

All information in this publication is based on the latest product information available at the time of publication. Illustrations & photographs in this publication are intended for reference use only & may not depict actual model component parts.

Conditions of purchase.

It is a condition of purchase that the following manual has been read & fully understood. The f350 / F500t / 2-seater karts are not designed for highway use. They must not be manufactured for resale or hired to the general public. Protective clothing & approved safety helmet & eye protection must be worn at all times. The karts must never be operated without supervision or in conditions that may cause danger or damage to people or property. Both the driver & supervisor must have read the owners manual & safety precautions before operating the kart. It is a condition of purchase, that Redwood Engineering (UK) Ltd will not accept any liability for accidents or injuries arising from building, maintaining, racing, driving or use of their karts or kart equipment. All karts & kart components are used at the drivers own risk;. Because of the unpredictable nature of off road karting, as with many other motor sport, all components are highly stressed & could fail without warning. Therefore with the exception to the engine, (Limited & dependent on make) no part of the kart or its parts are guaranteed, whatever the usage.



Redwood Eng. (UK) Ltd.,
Snowdon Rd. Nth.,
Queensway Ind. Est.,
St. Annes on Sea,
Lancs., FY8 3DP.

Tel: 0044 (0)1253 713266
Fax: 0044 (0) 1253 728233
Email : info@offroadkartplans.com
www.offroadkartplans.com

CONTENTS.



Conditions of purchase.
Important Notice for instructions.
Driver briefing.
(Code of good practice.)



Key to terminology, tools & equipment.
Workshop code of good practice.
Helpful tips & instruction notes.
Profile packs / parts packs.
Parts lists.



Frame construction.
Cutting lists.
Orthographic views.
General construction breakdown.
Frame & component construction.



Component list.
Parts pricelist.



Assembly manual.



Inspection & maintenance
manual.

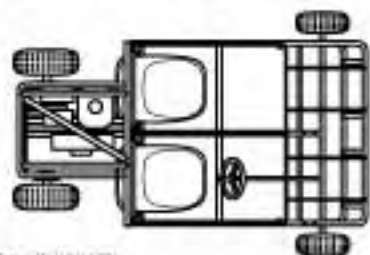

© Redwood Eng. (UK) Ltd. 1991



KEY TO TERMINOLOGY. Helpful tips & instruction notes.

Instruction notes.



Use a hammer to tap into place.



File to create tap fit.



Use a vice for this stage.



Use drill to create locating hole.



Use a known straight edge.



Use waterproof grease to lubricate

The following assembly manual is laid out in both illustrated & written instructions. It is recommended that you work at your own pace with each step being assembled methodically rather than rushed.

The instructions are numbered in order of assembly, with a list of each component needed for completion of each individual stage. All fixings required are illustrated in red for easy identification. Also featured are the above symbols, these give an indication of the assembly technique involved.

It is recommended that before each stage is attempted the required fixings, components & tools are gathered together within easy reach (with the required fixings in a suitable tub / container)

For example:

Components / Tools.



A pair of needle nosed pliers.
A set of spanners.
A set of Metric allen keys.



STEP Three & Four.



Grease & fit steering column with the solid nylon steering bush.

1 x 3/4 washer & split pin.

Mount the attached steering column bush in between the two front rear facing brackets on the front axle beam, with the column actuating arm facing downwards.

M8 x 55 soc cap & M8 washer & M8 nylock.

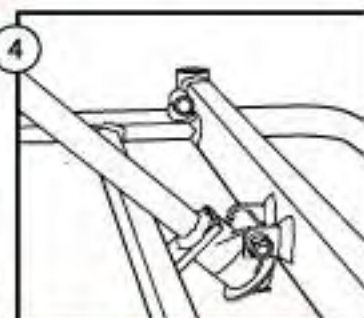



FRAME CONSTRUCTION. Orthographic Views.

2- Seater Rally Kart.

