



Redwood Eng. (UK) Ltd.,  
Snowdon Rd. Nth.,  
Queensway Ind. Est.,  
St. Annes on Sea,  
Lancs., FY8 3DP.

Tel: 0044 (0)1253 713266  
Fax: 0044 (0) 1253 728233  
Email : info@offroadkartplans.com  
www.offroadkartplans.com

## BUILD YOUR OWN RALLY KART

OPTIONS :WASP F350 /WASP F500T.

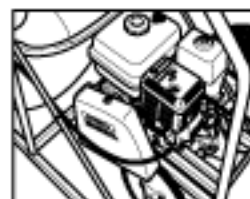

Fully illustrated  
build manual.

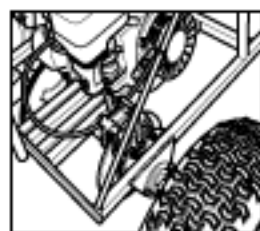

Step by step  
assembly  
&  
maintenance  
manual.



Parts pricelists  
&  
kit prices.



### Features include:

Fully illustrated plans & build manual, includes drawings & written instructions.

Maintenance & Inspection manual, a complete guide to servicing is included with every plan set.

Full technical advisory service for all your kart build questions.

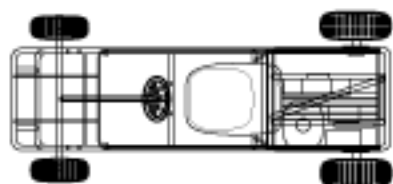



# FRAME CONSTRUCTION.

Orthographic Views.

**F350 Fun Kart.**

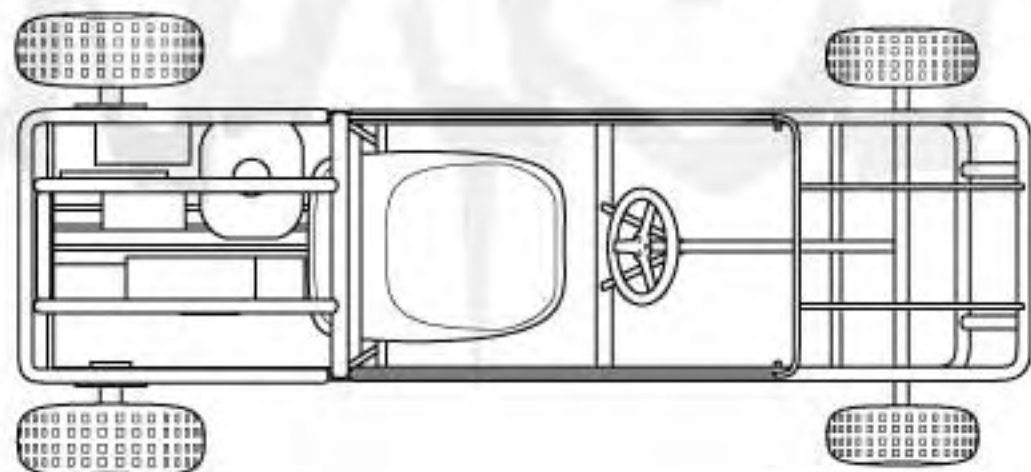
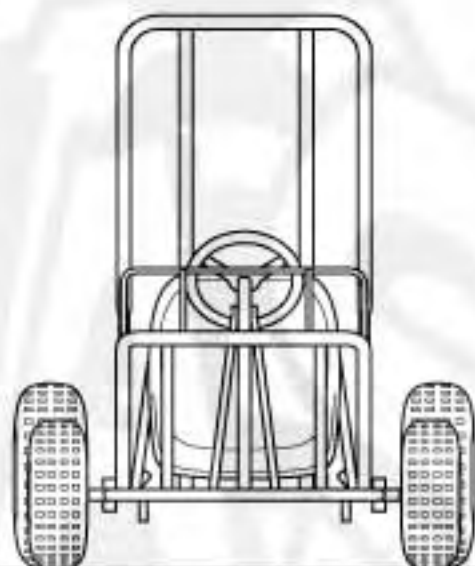
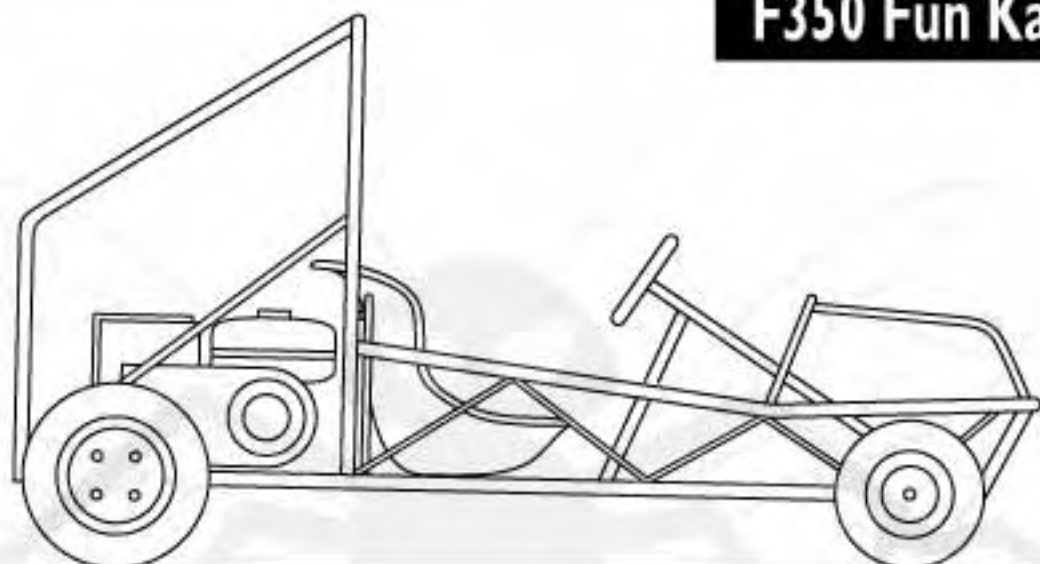



# KEY TO TERMINOLOGY.

## Helpful tips & instruction notes.

### Instruction notes.



Use a hammer to tap into place.



File to create tap fit.



Use a vice for this stage.



Use drill to create locating hole.



Use a known straight edge.



Use waterproof grease to lubricate.

The following assembly manual is laid out in both illustrated & written instructions. It is recommended that you work at your own pace with each step being assembled methodically rather than rushed.

The instructions are numbered in order of assembly, with a list of each component needed for completion of each individual stage. All fixings required are illustrated in red for easy identification. Also featured are the above symbols, these give an indication of the assembly technique involved.

It is recommended that before each stage is attempted the required fixings, components & tools are gathered together within easy reach (with the required fixings in a suitable tub / container)

For example:

#### Components / Tools.



A pair of needle nosed pliers.  
A set of spanners.  
A set of Metric allen keys.



#### STEP Three & Four.

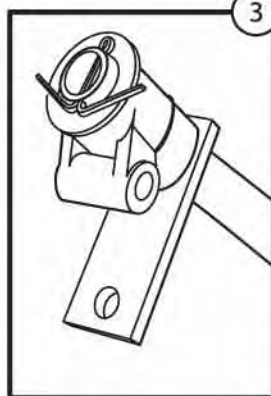

Grease & fit steering column with the solid nylon steering bush.  
1 x 3/4 washer & split pin.

Mount the attached steering column bush in between the two front rear facing brackets on the front axle beam, with the column actuating arm facing downwards.

M8 x 55 soc cap & M8 washer & M8 nylock.

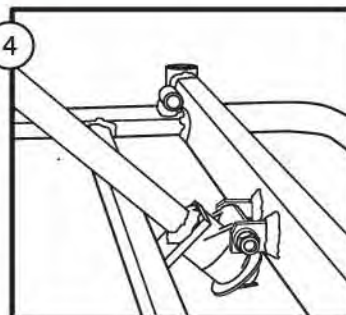



HOTTIP

Stand frame on a kind & level surface, such as an old carpet. This will stop the newly painted frame from being scratched.

If you have problems fitting the bushes remove any flashing or paint from the inside of & the top of the king pin tubes.

If you wish you may tap home the king pin bushes with a hammer. Make sure you that you hit the bush squarely. Do not use too much force.

# General Assembly Part One.

## Components.



- 2 large adjustable spanners.
- or
- 1 large adjustable spanner.
- A hammer.



## STEP One & Two.

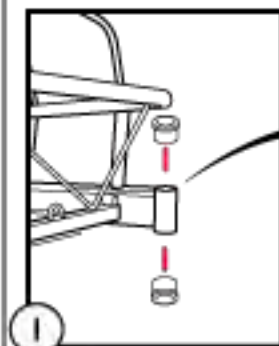

- Stand frame on end & secure.
- Press 4 x 3/4" king pin bush into front axle tubes top & bottom.

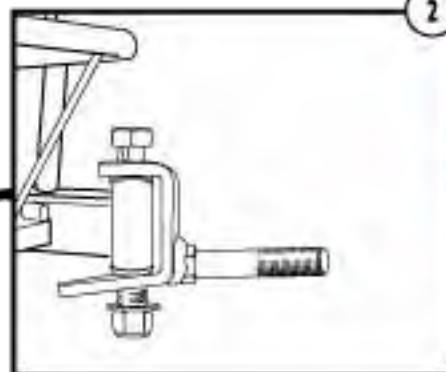

- Grease & mount front stub axles left & right.
- 3/4" x 5" H.T hex bolt, 3/4" washer, stub axle, 3/4" washer, 3/4" nylock nut.
- Tighten until solid then back off the nylock to provide movement.

## Components.



- 1 pr of pliers / needle nosed.
- 1 open spanner.
- A set of Allen keys.



## STEP Three & Four.

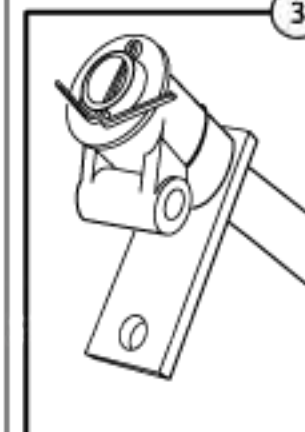

- Grease & fit steering column with the solid nylon steering bush.
- 1 x 3/4 washer & split pin.

Mount the attached steering column bush in between the two front rear facing brackets on the front axle beam, with the column actuating arm facing downwards.

- M8 x 55 soc cap & M8 washer & M8 nylock.

